

## PR-57 Series

High Pressure Corrosion-resistant Regulator (10,000 psig Inlet)



To meet the demands for the safe reduction of inlet pressures up to 10,000 psig, GO Regulator has designed the PR-57 Series regulator. This precision regulator features a piston sensing design which provides the operator with low adjusting torque requirements when setting the outlet pressure. The body is constructed from 316L stainless steel, providing the ultimate in safety and corrosion resistance.

The optional self-relieving feature provides an additional level in operational ease, as it allows for trapped downstream pressure to be safely vented to atmosphere through the bonnet.

### Features & Specifications

- Gas or liquid service
- 316L stainless steel construction
- Better than 25 Ra finish in diaphragm cavity
- Stainless steel spring loaded piston sensor
- 20 micron filter
- Bubble-tight shutoff
- Viton® seals (other elastomers optional)
- Inlet pressure maximum 10,000
- Outlet pressure ranges are 0–250, 0–500, 0–750, 0–1000, 0–2000, 0–4000, 0–6000, 0–7500 and 0–10,000 psig
- 1/4" FNPT standard
- Operating temperatures -40° F to +150° F (-40° C to +66° C)
- Cv flow coefficient 0.05 or 0.2

### Options

- Gauges and CGA fittings for cylinder gas application
- Self-relieving and captured vent
- 3/8" FNPT

pressure regulators

# PR-57 Series

To Order, contact your local Distributor Link below:  
[www.goreg.com/distributor/index.htm](http://www.goreg.com/distributor/index.htm)

Verify that your chosen part number is valid using the GO Wizards at  
[www.goreg.com/products/matrix/index.htm](http://www.goreg.com/products/matrix/index.htm)

## How to Order

### PR57 –

#### BODY MATERIAL

- 1 316L stainless steel
- 4 MONEL®

#### PORT CONFIGURATION

- A Standard
- For more port configurations, see page 33.

#### PROCESS PORT TYPES

(GAUGE PORT TYPES, IF SPECIFIED)

- 1 ¼" FNPT (¼" FNPT gauge ports)
- 4 ⅜" FNPT (¼" FNPT gauge ports)

#### SURFACE FINISH OF DIAPHRAGM CAVITY

- 1 < 25 Ra
- 5 < 25 Ra with 10-32 mounting holes

#### SEAT MATERIAL

- C Polyimide
- Q PEEK™

#### FLOW COEFFICIENT (Cv)

- 2 0.05
- 5 0.2

#### OPTIONS

- B EB5
- D Helium leak test
- E Pressure test certificate
- F Certificate of Conformity
- G CMTR

#### CAP ASSEMBLY

- 1 Standard, aluminum
- 4 Panel mount, aluminum
- 5 Captured vent, aluminum
- 6 Captured vent, panel mount, aluminum
- 7 Captured vent, stainless steel
- 9 Plastic knob, stainless steel
- A Captured vent, plastic knob, stainless steel
- B Panel mount, plastic knob, stainless steel
- F Stainless steel
- V Captured vent, panel mount, stainless steel
- W Panel mount, stainless steel

#### PISTON MATERIAL

- 4 Stainless steel/PTFE cavity O-ring
- 5 Stainless steel/Viton® cavity O-ring
- 6 MONEL®/Viton® cavity O-ring
- 7 MONEL®/PTFE cavity O-ring

#### PISTON TYPE

- 1 Non-self-relieving
- 3 Self-relieving

#### OUTLET RANGE

- I 0-250 psig
- J 0-500 psig
- W 0-750 psig
- K 0-1000 psig
- L 0-2000 psig
- N 0-4000 psig
- O 0-6000 psig
- P 0-7500 psig
- Q 0-10,000 psig

NOTE: Contact the factory for any additional requirements.

## Maximum Temperature & Operating Inlet Pressures

SEAT MATERIAL	MAXIMUM TEMPERATURE	@	MAXIMUM OPERATING INLET PRESSURE
Polyimide	150° F (66° C)	@	10,000 psig (68.95 MPa)
PEEK™	150° F (66° C)	@	10,000 psig (68.95 MPa)

## Outline and Mounting Dimensions

Weight = 4.4 lbs (2.0kg)

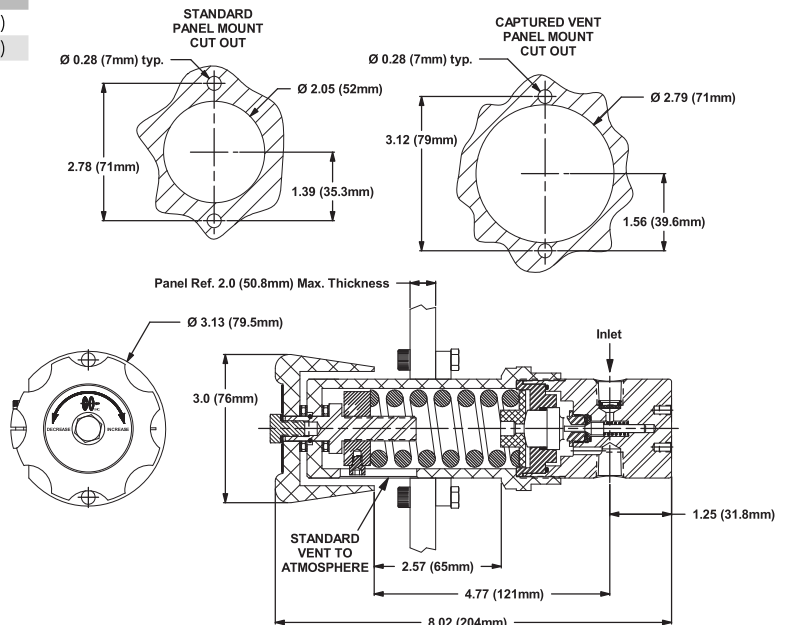

MONEL® is a registered trademark of Special Metals Corporation.  
 PEEK™ is a trademark of Victrex PLC.